

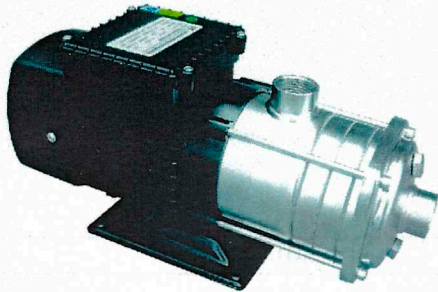

YDH series

HORIZONTAL MULTI-STAGE CENTRIFUGAL PUMP MANUAL INSTRUCTION

Please clearly read the manual before using the pumps



1. APPLICATION

Mainly applicable for conveying of industrial liquid, such as mineral water, soft water, pure water, clean oil and circulation and boosting for other weak chemical-industrial medium.

- Cold water chiller cooling cycle
- Water treatment processes
- Industrial cleaner and dishwasher
- Water boosting on process
- Heating and cooling for industrial process
- Air-conditioning system
- Air freshening, heater device (soft water)
- Water supply and boosting (drinking water, light chlorine water)
- Fertilization/metering system

2. WORKING CONDITIONS

- Liquid temperature:
- low temperature: $-20^{\circ}\text{C} \sim +70^{\circ}\text{C}$;
- standard model: $+15^{\circ}\text{C} \sim +70^{\circ}\text{C}$;
- high temperature: $+70^{\circ}\text{C} \sim +104^{\circ}\text{C}$;
- Max. environmental temperature: 50°C
- Max. operating pressure: 8 bar
- Max. suction pressure is limited by max. Operating pressure

3. MOTOR

- 2-pole induction motor;
- three-phase: 220/380V/50Hz; 380/660V/50Hz
- Single-phase: 220~240V/50Hz,
- Single-phase with input thermal protector
- Insulation class: F
- Protection: IP55
- Continuous duty

4. CONNOTATION OF THE TYPE

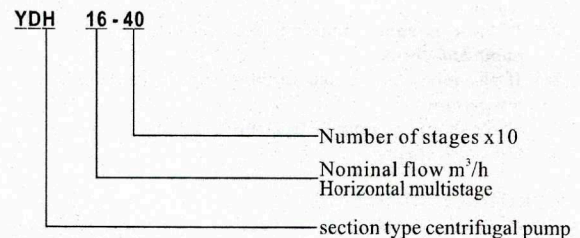

5. INSTALLATION

Notice: ⚠

- 5.1. Do not install the pump in the sunbaked or wet place.
- 5.2. Install the pump to near the water source as short as possible to have a shortest suction pipe and prevent from reducing the suction.
- 5.3. Position the pump using the brackets.
- 5.4. Install the pump in dry and ventilated place to ensure safe operation.
- 5.5. Try to reduce the bend in pipe circuit as you can, the gradient should less than 2%.
- 5.6. The connection of pipe circuit should be water-tight, the pipes should be supported separately.
- 5.7. It's appreciated to install a vacuum meter and pressure gauge in the suction and discharge to observe the situation of operation.

6. ELECTRIC CONNECTION

Danger: ⚠

- 6.1. Ensure the voltage (V), frequency (Hz), phase (PH) is conform with the ones marked on the label. When the Voltage $\pm 10\%$, it will make the inset thermal protector operate and the motor stop operating.
- 6.2. Pump should be reliably earthed and with leakage protection switch.
- 6.3. The cord should meet the requirements of current.
- 6.4. Make sure the correct electric connection according to the wiring diagram.

7. START, OPERATION AND STOP THE PUMP

Warning: ⚠

- 7.1. Dry operation is prohibited to avoid burning of mechanical seal.
- 7.2. It could rotate freely from the fan cover by screw driver.
- 7.3. Turn on the pump, it should be clockwise view from the fan cover.
- 7.4. Fill water in the pump from the discharge valve.
- 7.5. Turn on the pump, open the discharge valve to set the flow and discharge pressure to the required data.
- 7.6. Close the discharge valve before stopping the pump and power.

8. MAINTENANCE

Notice: ⚠

- 8.1. It is prohibited to start the pump frequently, it should disconnect the switch when the power supply is suddenly interrupt.



YDH series

HORIZONTAL MULTI-STAGE CENTRIFUGAL PUMP MANUAL INSTRUCTION

- 8.2. It is not allowed to use the suction valve to adjust flow.
- 8.3. When the water is insufficient, it should stop the pump.
- 8.4. If there is some abnormal noise, please stop the pump and check.
- 8.5. If the pump is not use for long time or stop in low temperature, water should be drained to avoid damaging the pump body as freezing.

9.TROUBLE SHOOTING

PROBLEMS	POSSIBLE REASONS	SOLUTION
The pump does not run	The voltage is not correct. Fuse or thermal protector makes the pump stop running.	Check the voltage on the name plate. Check the fuse or thermal protector.
The pump does not pump properly	Too much high head Too low water level Bottom valve not in water No water Leakage of inlet pipe	Check the suitable head. Check the suction head. Have the valve in the water. Fill the pump with water. Check the suction conditions.
The pump runs but no water	The foot-valve is blocked. The impeller is corrosive. The bottom valve is not in the water. No priming water. Leakage in suction pipe.	Check the suction height and re-install the pump. Replace the impeller. Fill the suction section with water. Fill the pump with water. Check the suction conditions.
The flow reduces obviously	The foot-valve is blocked. The head is too high. The water level is too low. The impeller is serious damage.	Clean or replace the foot-valve. Check the installation height. Check the suction head and re-install the pump. Replace the impeller.
The motor is over heating	Low voltage or insufficient ventilation in pump room	Contact the electric power company to supply stable voltage. Have good ventilation.
The pump stops soon after starting	Low voltage or insufficient ventilation in pump room	Contact the electric power company to supply stable voltage. Have good ventilation.

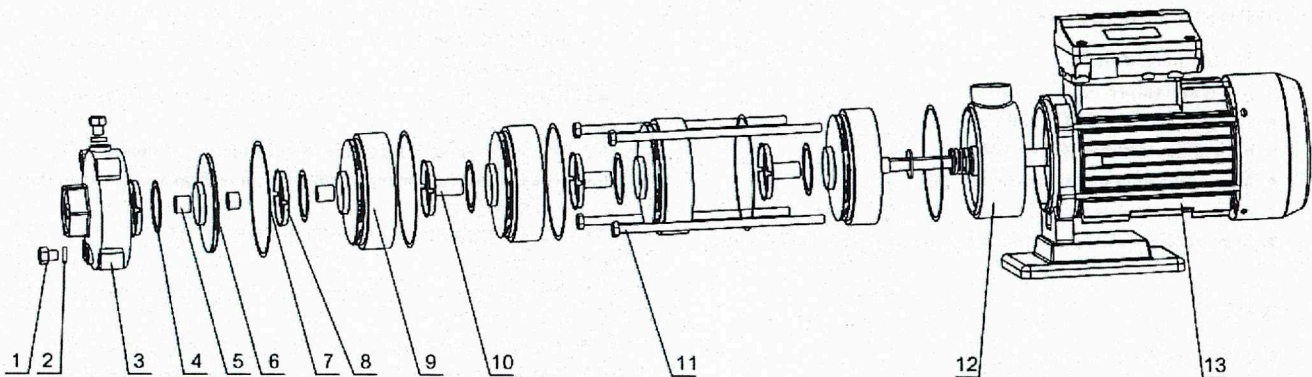

NO.	DESCRIPTION	NO.	DESCRIPTION	NO.	DESCRIPTION
1	Drain Plug	6	Impeller	11	Tension Bar
2	Plain Washer	7	Gasket	12	Discharge Body
3	Suction Body	8	Mouth Piece Outer Ring	13	Motor
4	Impeller Seal Ring	9	Diffuser Assembly		
5	Shaft Sleeve	10	Shaft Sleeve		