

## JST SELF-PRIMING STAINLESS STEEL MULTISTAGE CENTRIFUGAL PUMP INSTRUCTION MANUAL

Please clearly read the manual before use the pumps

### 1. FEATURES

JST series self-priming stainless steel multistage centrifugal pumps: impeller and diffuser are made of PPO engineering plastic, SUS304 stainless steel pump casing, advanced design, high head, high efficiency, endurance, etc.

JST series pumps belong to self-priming horizontal multistage centrifugal pumps, axial inlet and radial outlet, attached with long shaft electric motor.

JST series pumps is suitable for agriculture, industry, air-conditioning, cooling system, industrial washing, water treatment ( water purification ), high building boosting, water supply, garden sprinkler, fishing, and so on.

### 2. OPERATION CONDITIONS

JST series pump is suitable for non-fire, non-flammable clean liquid which keep away from corrosive of PPO plastic. The liquid temperature: from +0 °C to 70 °C, max ambient temperature: +50 °C, max suction: 8 meter; max working pressure: 1Mpa, the max input pressure is limited by the max working pressure.

### 3. MODEL SYMBOL

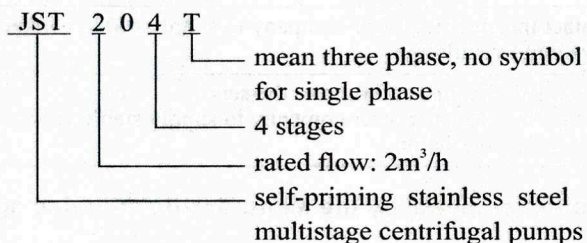

### 4. INSTALLATION

Notice: ⚠

- 4.1. Do not install the pump in the sunbaked or wet place.
- 4.2. Install the pump to near the water as short as possible to have a shortest suction pipe and prevent from reducing the suction.
- 4.3. Position the pump using the brackets.
- 4.4. Install the pump in dry and ventilated place to ensure safe operation.

- 4.5. Try to reduce the bend in pipe circuit as you can, the gradient should less than 2%.
- 4.6. The connection of pipe circuit should be water-tight, the pipes should be supported separately.
- 4.7. It's appreciated to install a vacuum meter and pressure gauge in the suction and discharge port to observe the situation of operation.

### 5. ELECTRIC CONNECTION

Danger: ⚠

- 5.1. Ensure the voltage (V), frequency (Hz), phase (PH) is conform with the ones marked on the label. When the Voltage  $\pm 10\%$ , it will make the thermal protector operate and the motor stop operating.
- 5.2. Pump should be reliably earthed and with leakage protection switch.
- 5.3. The cord should meet the requirements of current.
- 5.4. Make sure the correct electric circuit.

### 6. START, OPERATION AND STOP THE PUMP

Warning: ⚠

- 6.1. Dry operation is prohibited to avoid burning of mechanical seal.
- 6.2. It could rotate freely from the fan cover by screw driver.
- 6.3. Turn on the pump, it should be clockwise view from the fan cover end.
- 6.4. Fill water in the pump from the discharge valve.
- 6.5. Turn on the pump, and set the discharge pressure to the required.
- 6.6. Close the discharge valve before stopping the pump and power.

### 7. MAINTENANCE

Notice: ⚠

- 7.1. It is prohibited to start the pump frequently, it should open the switch when the power is interrupt.
- 7.2. It is not allowed to use the suction valve to adjust flow.
- 7.3. When the water is insufficient, it should stop the motor.
- 7.4. If there is some abnormal noise, please stop the motor and check.
- 7.5. If the pump is ideal for long time or low temperature, water should be drained to avoid damaging the pump body as freezing.

## 8. INSTALLATION SIZE

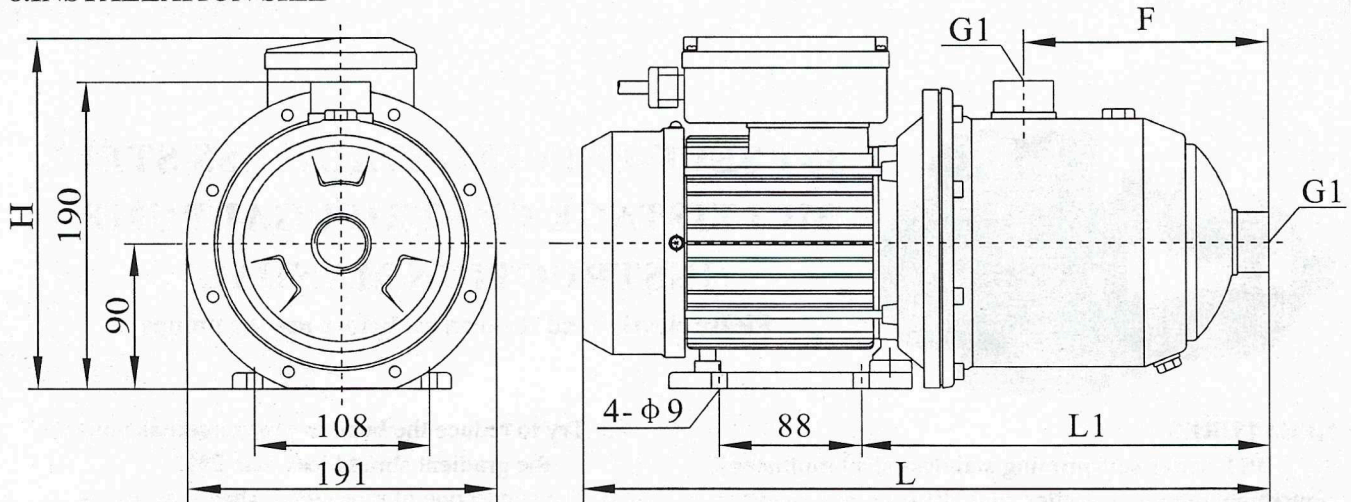

## 9. TROUBLE SHOOTING GUIDE

PROBLEMS	POSSIBLE REASONS	SOLUTION
The pump does not run	The motor is rocked. The voltage does not match. Fuse or thermal protector makes the pump stop running.	Send to the service center. Check the voltage on the name plate. Check the fuse or thermal protector.
The pump does not pump properly	The head is too high. The water level is too low. The bottom valve is not in the water. No water. The inlet pipe is leakage.	Check the height of installation if it meets the head. Check the suction height. Have the valve in the water. Fill the pump with water. Check whether the pipe is leakage.
The pump runs but no water	The foot-valve is blocked. The impeller is corrosive. The bottom valve is not in the water. No priming water. The inlet pipe is leakage.	Check the suction height and re-install the pump. Replace the impeller. Fill the inlet section with water. Fill the pump with water. Check whether the pipe is leakage.
The flow reduces obviously	The foot-valve is blocked. The head is too high. The water level is too low. The impeller is serious damage.	Clean or replace the foot-valve. Check the height of installation whether is the same as normal doing. Check the suction height and re-install the pump. Replace the impeller.
The motor is over heat	The voltage does not match. Bad ventilation in the operation room.	Contact the electric power company to supply stable voltage. Have good ventilation.
The pump stops soon after starting	The motor is locked. The voltage is too low. Bad ventilation in the operation room.	Disconnect the pipe and send to the service center. Contact the electric power company to supply stable voltage. Have good ventilation.



**Type y attachment - damaged supply cords to be replaced by the Manufacturer, service agent or similarly qualified person To avoid hazard.**